

MODEL NUMBER	IXHHI20-18-256T		
HORSEPOWER	20		
RPM / POLES	1800 / 4		
VOLTAGE / PHASE	230 / 460 V / 3		
FRAME	256T		
ENCLOSURE / DEGREE OF PROTECTION	TEFC / IP54		
FREQUENCY	60 HZ		
FULL LOAD SPEED	1775 RPM		
SERVICE FACTOR	1.15		
INSULATION CLASS	F Class N Varnish		
FULL LOAD AMPS; 230 / 460	49.7 / 24.8 A Usable On 208 V At 55.0 A		
LOCKED ROTOR CURRENT (% Full Load)	680 / 680 %		
NEMA CODE LETTER	H		
EFFICIENCY / POWER FACTOR	<u>LOAD</u>	<u>EFF.</u>	<u>P.F.</u>
	100 %	93.0 %	81.5 %
	75 %	93.0 %	78.0 %
	50 %	92.0 %	70.0 %
DUTY CYCLE	S1 / Continuous		
TORQUE	<u>FULL LOAD</u>	<u>LRT</u>	<u>BDT</u>
	59.5 lb.ft.	200 %	240 %
NEMA DESIGN	B		
MOMENT OF INERTIA	<u>LOAD (Max.)</u>	<u>MOTOR</u>	
	303.750 lb.ft. <sup>2</sup>	2.635 lb.ft. <sup>2</sup>	
SOUND PRESSURE LEVEL ( No Load 1 M From Motor)	74 dB(A)		
MAX. SHAFT VIBRATION	0.08 In/Sec – Peak Velocity		
NUMBER OF STARTS (Hot / Cold)	2 Hot / 3 Cold		
MAX. ELEVATION	3300 Ft. Above Sea Level		
TEMPERATURE RISE (At Full Load)	80° C		
DRIVE-END BEARING	6309ZC3		
OPPOSITE DRIVE-END BEARING	6309ZC3		
GREASE TYPE	Mobil Polyrex EM		
MOUNTING	F1, W6, W8, B3, V5, V6		
ROTATION	Bi-Directional		
APPROXIMATE WEIGHT	350 lbs.		
AREA CLASSIFICATION	Class I, Division 1, Groups C and D		
TEMPERATURE CODE WITH THERMOSTAT USE	T4		
TEMPERATURE CODE AT 40°C AMBIENT	T2C		
TEMPERATURE CODE AT 55°C AMBIENT	T2B		
THERMOSTAT TYPE	Normally Closed		
INVERTER RATING	4:1 CT (Constant) / 10:1 CT (Intermittent-1 Hour) / 10:1 VT		
INSULATION TYPE	Hyundai Inverter Shield, Meets NEMA MG1 Part 31		
UL CERTIFICATION NUMBER	E216236		





# TEFC

**THREE PHASE INDUCTION MOTOR**

**TYPE**

XLP, XJP

CAST IRON FRAME

FRAME SIZE

OUTPUT(HP)

POLES

Hz

TIME RATING

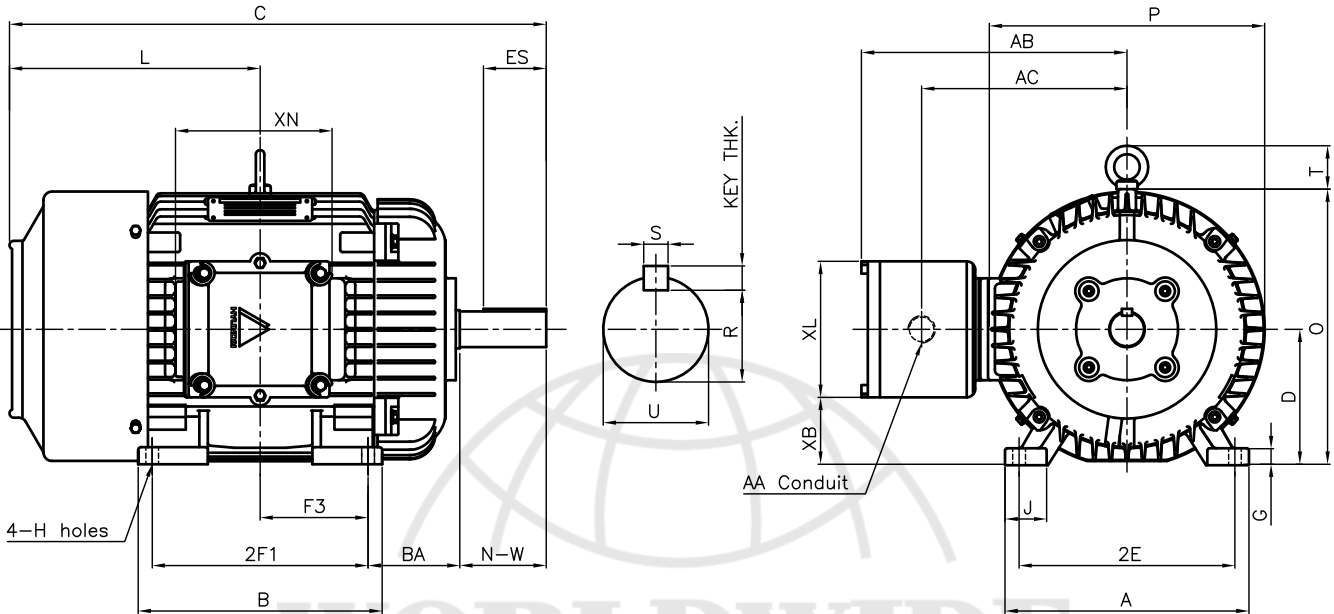

## DIMENSIONS

MOUNTING									CONDUIT BOX						APPROX. WGT.(LB)
A	B	2E	2F1	2F2	F3	G	J	H	AA	AB	AC	XA	XL	XN	
11.30	11.30	10.00	10.00	-	5.00	0.72	1.93	0.53	1.25	12.01	9.51	3.15	6.30	7.32	350

OVERALL							SHAFT					KEY THK.	BEARING	
BA	C	D	L	O	P	T	U	N-W	KEYWAY				DRIVE END	OPP. DRIVE END
									R	ES	S			
4.25	24.86	6.25	11.61	12.75	12.76	2.01	1.625	4.00	1.416	2.91	0.375	0.375	6309ZC3	6309ZC3

**NOTE**

- 1.Dimension "D" tolerance : +0.00inch - 0.03inch
- 2.Dimension "U" tolerance : +0.000inch - 0.001inch
- 3.Dimension "R" tolerance : +0.000inch - 0.015inch

APPD BY	J. H. KIM	UNIT	INCH	SUBJECT	NEMA 256T	CAD PROJ \ FILE	XSMOUTN\A1108AA	
CHKD BY	K. S. LEE	SCALE	1/8					
CHKD BY		PROJEC'N	3rd Angle	TITLE				OUTLINE
DSND BY	KIM IN KYU	DATE	2010.12.31					
				REF. NO	A1108AA	Sheet No. of		
				DWG NO	LM-U1256B3TL001	Revision No. 0		